





SLIDING GATE OPERATORS

Centurion Systems' range of technologically-advanced sliding gate operators has been designed to automate virtually any sliding gate and suit a wide variety of applications; from private residences where the gate is only operated infrequently, to large complexes, businesses and industrial installations where the gate could almost be used constantly. All our operators offer functionality far beyond the scope of simply opening and closing your gate, putting a world of control literally at your fingertips.



SLIDING GATE OPERATOR QUICK SELECTION GUIDE

This quick selection guide will help you to select the perfect CENTURION for you or your client's sliding gate by providing the differentiating features and key specifications of each.



	D2 Turbo	D2 Turbo Low-Voltage	D5-Evo	D5-Evo Low-Voltage
Input voltage	90V - 240V AC / Solar	10V - 20V AC 10V - 28V DC	90V - 240V AC / Solar	15V - 19V AC 21V - 26V DC
Mains power required at gate	√ / Solar	-	√ / Solar	-
Gate mass – maximum	250kg	250kg	500kg	500kg
Gate speed – maximum	227mm/sec	400mm/sec	367mm/sec	400mm/sec
Duty cycle – mains present	Domestic use ¹	Domestic use ¹	Light-industrial ¹	Domestic use ¹
Daily operations - maximum	10 ²	10 ²	150 ²	150 ²
Interface type	Dial-based	Dial-based	LCD	LCD
Time-barring and automatic activation	-	-	√	√
Onboard multichannel receiver	√	√	√	√

1. Based on a 25° ambient temperature and unit not in direct sunlight

2. Battery-driven typically using a 7Ah (5Ah – D2 Turbo/D2 Turbo Low-Voltage) battery and a charger (battery can be upgraded for greater power failure autonomy – mounted separately). Solar power may also be used.



D5 SMART	D10	D10 Turbo	A10 Endurance		A10 Heavyweight
15V - 19V AC 21V - 26V DC	90V - 240V AC / Solar	90V - 240V AC / Solar	220V - 240V AC		220V - 240V AC
-	√ / Solar	√ / Solar	√		√
500kg	1000kg	1000kg	Standard speed 1000kg	Sprint speed 600kg	2000kg
500mm/sec	433mm/sec	833mm/sec (varies with load)	Standard speed 267mm/sec	Sprint speed 500mm/sec	227mm/sec
Domestic use ¹ 150 ²	Industrial ¹ 750 ^{2,3}	Industrial ¹ 750 ^{2,3}	Heavy-industrial Only limited by duty cycle		Heavy-industrial Only limited by duty cycle
Mobile app	LCD	LCD	LED-based		LED-based
√	√	√	-		-
√	√	√	-		-

3. With a brush replacement interval of two years



INTELLIGENT SECURITY FOR YOUR GATE

D5 SMART

SMART.
The intelligent choice.

*What makes the **D5 SMART** so smart? Well, lots of things, but wireless convenience is where this operator really shines!*



SMART ACCESS TO YOUR HOME

Combining futuristic technology with the user-friendly design that has become the hallmark of CENTURION's gate automation solutions, the D5 SMART is equal parts sophistication and simplicity.

Boasting wireless convenience and fast operating speed for greater security, not to mention a host of advanced features, the D5 SMART has everything you ever wanted in a gate motor... and more!

SMART speed

At 30m/minute and with safe anti-crushing protection, the D5 SMART strikes the perfect balance between safety and security.

SMART connectivity

Open your gate from anywhere using your smartphone, plus set up unique, individual profiles for everyone using the gate.

SMART diagnostics

Self-testing functionality measures and monitors the system's performance.

SMART hardware

We'll have you sliding in no time thanks to simplified installation.

SMART logging

The D5 SMART provides intelligent feedback on your operator's overall functioning and reports on events such as the last remote pressed, the condition of the battery, gate status as well as the speed at which the gate is running, delivering maximum peace of mind and giving you the SMART experience.



D5 SMART DOMESTIC SLIDING GATE OPERATOR

Our brand essence is “making your life easier” and, with the D5 SMART, we believe that we have created a product that is the very embodiment of this. Taking what we’ve learned through more than 30 years of being the market leader in access automation, we are bringing you a solution that gives you everything from intelligent reporting to easy mobile-based setup and operation, as well as SMART hardware for a greatly simplified mechanical installation.

With unsurpassed convenience and control at your fingertips, you’ll love using the D5 SMART.



MAIN FEATURES

- Wireless and effortless – easy smartphone setup and configuration
- Safe and secure with a top speed of 35 metres per minute
- Makes your life easier with advanced diagnostic feedback
- Dependable battery backup – continues working during power outages
- Intelligent logging and reporting
- Onboard multichannel NOVA receiver with 1500 remote memory
- SMART hardware providing best experience for installers and end-users
- New and improved theft-resistant cage with a patented design offering outstanding security and peace of mind
- Intelligent battery charger with onboard diagnostics and SMART communication between the charger and the controller
- Improved position control system incorporating hall effect technology – highly resistant to interference
- Individually-configurable inputs and outputs
- Convenient and intuitive single-action manual release

TECHNICAL SPECIFICATIONS

Technical Data	D5 SMART
Input voltage	90V - 240V AC +/-10% @ 50Hz ¹
Current consumption (Mains)	200mA
Battery charger current output	1.3A
Maximum number of operations per day	150
Duty cycle - Mains present ^{2,3}	50%
Motor voltage	24V DC
Motor power supply	Battery-driven (Standard Capacity - 2x12V) ⁵
Current consumption (motor at rated load)	13A
Input / Output sink currents (Max accessory current draw)	
I/O 1-4	100mA (12/24V)
I/O 5 and 6	3A (12/24V) 10sec Pulse
Motor push force - starting	30kgf
Motor push force - rated	17kgf
Gate mass - maximum	500kg
Gate length - maximum	100m
Gate speed (varies with load) ⁴	30m/min @ 17kgf
Manual Override	Lockable with key release
Operations in standby with 6Ah battery	
Half day ^{5,6}	44
Full day ^{5,6}	35
Collision Sensing	Electronic
Operating temperature range	-15°C to +50°C
Onboard receiver type	Code-hopping multichannel receiver with selective add and delete
Receiver code storage capacity	1500 Remotes ⁷
Receiver frequency	433.92MHz
Degree of protection	IP55
Mass of unit packed	9.1kg

1. Can operate off a solar supply, consult your local dealer for assistance
2. Based on 25°C ambient temperature and unit not in direct sunlight
3. Based on a motor push force of less than 50% of rated (Starting and Running forces)
4. Gate opening and closing speeds can be configured to run slower depending on the requirements of individual installations
5. Can increase battery capacity for longer standby times
6. Based on 4m gate, excluding all accessories
7. Multiple buttons per remote can be used

D5 SMART single operator duty cycle as a function of operating time

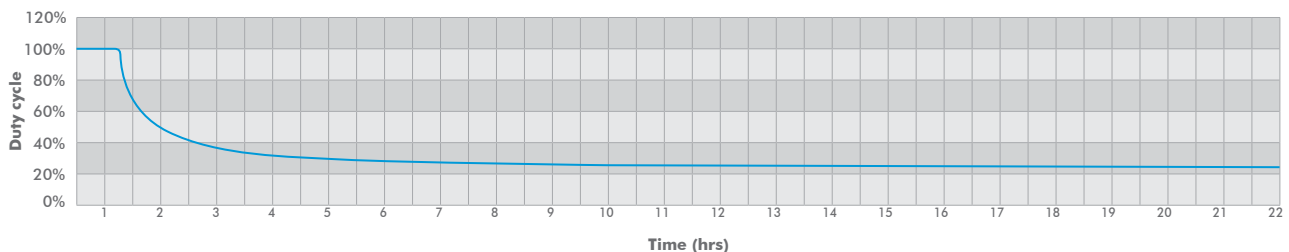



CABLING REQUIREMENTS

1. **D5 SMART:** 220V - 240V AC mains cable via double mains isolator switch (3 core LNE 1.5mm² SWA)¹

Optional Wiring (all cable is multi-stranded):

2. Intercom, cable from control box to dwelling (n1⁶ + 6 core³ 0.5mm² multi-stranded) or cable from control box to entry panel (n2⁶ 0.5mm² multi-stranded)
3. Infrared Safety Beams (3 core 0.5mm² multi-stranded)
4. Access control device (3 core 0.5mm² multi-stranded⁴)
5. Pedestrian keyswitch (2 core 0.5mm² multi-stranded) or
6. Keypad (3 core 0.5mm² multi-stranded)
7. External radio receiver (3 core 0.5mm² multi-stranded⁵)
8. Pillar Lights (3 core LNE SWA², size according to power requirements)
9. Inductive loop detector for free-exit (1 core 0.5mm² multi-stranded - silicone-coated⁶)

1. Possibly increase cable thickness if Pillar Lights are to be installed
2. SWA - steel wire armoured. Type of cable must adhere to municipal bylaws and preferably be screened. Screening provides better protection against lightning - earth one end of the screening
3. Allows for all features such as Pedestrian Opening, Status LED, etc. to be operated from the intercom handset inside the dwelling

4. Number of cores and type of cable could vary depending on the brand of access control system being used

5. For optimum range an external radio receiver can be mounted on the wall

6. Number of cores required by the intercom



CHOOSING THE RIGHT GATE MOTOR



Let's say, hypothetically, that you have finally grown tired of your old jalopy and you're in the market for a new, more reliable, mode of transportation. Naturally, there are a number of factors you would consider and things you would weigh up before finally settling on a car.

Is safety an important consideration for you? Are you in the market for a family sedan or a sports hatch? Are you looking for something with superior fuel economy?

Similarly, when you're preparing to have your world rocked by the amazing security and convenience provided by a gate motor, there are some things you need to think about to ensure that you get one that's right for your application. But don't worry, with some handy tips from your favourite access automation company you'll be wielding that remote like a magical sceptre in no time..

AC or DC

We're not referring to the Australian rock band of course (although our gate motors have been known to rock!), but rather to the form in which electric power is supplied to your operator. AC, or alternating current, means that the gate motor is being powered directly via the 230V mains supply from a distribution board in your house.

DC, or direct current, on the other hand, is a method of power delivery relying on some sort of "power store" such as a battery. You'll find that the vast majority of CENTURION gate motors are DC-operated.

And there's a good reason for that. Power delivery, especially in South Africa, is unfortunately quite unreliable and we've all borne the brunt of load shedding before. Your gate motor, being the holder of so many titles – security guard, butler, etc. – needs to be on duty around the clock, and DC units are able to continue operation even during lengthy power failures, whereas AC gate motors are not.

On the flipside of the coin, AC motors have a virtually unlimited duty cycle and will work tirelessly as long as they are being fed mains. Both of these modes of power delivery have their virtues, you simply need to decide which is best suited for your application. If you live in an area where power outages are commonplace, a DC unit is probably the best bet.

Weight of the Gate

Unless you're an ant or former Governor of California (and sometimes actor) Arnold Schwarzenegger, you probably can't carry much more than your body weight. But through the miracle of engineering gate motors are able to relatively effortlessly lug around several hundred times its own weight.

But that doesn't mean it should be unrealistically loaded. Subjecting it to that kind of abuse will invariably lead to problems down the line, so first get an approximation of what your gate weighs before selecting a motor. The good news is that gates are usually much, much lighter than we think. For example, if you can lift your gate to about the height of your shin, chances are it doesn't weigh much more than 250kg.

Pull Force

This is more an extension of the previous point than a whole new heading. Pull force plays a monumental role in what gate motor you install, and has a direct impact on both the reliability and the service life of the operator. If you struggle to open and close your gate manually, be sure to choose a device rated for a high push force such as a D10.

The easiest and most accurate way to determine the weight of the gate is to use a pull scale as found in any angling goods store.

Swing or Slide

This one might seem fairly obvious if you already have a gate fitted, but if you're looking to install a gate where there isn't currently one this might warrant some thought. The truth is that both swing and sliding gate motors are equally rich in merit and which one you choose to fit simply depends on preference or, in the case of an existing gate, what the setup necessitates.

If you are going with a swing gate, remember to take into account factors like the length of the individual leaves, wind loading, etc.

If you follow these few simple selection guidelines you're assured of a gate motor that'll faithfully serve you for years to come. And if you do get stuck, remember that our technical support centre is open Monday to Friday from 7am until 6pm. They're number is +2711 699 2451.



D2 TURBO AND D2 TURBO LOW-VOLTAGE DOMESTIC SLIDING GATE OPERATORS

The **D2 Turbo** is a high-speed, cost-effective operator for domestic gates weighing up to 250kg, with a maximum speed of 400 millimetres per second and powerful peak push force rated at 9kgf. This operator is exceptionally quick and easy to install and set up, with all settings easily configurable via two dials on the controller. With loads of features, the **D2 Turbo** is the complete motor for a standard, domestic four metre gate.

The **D2 Turbo Low-Voltage** operator is designed specifically for sites with no mains at the gate to reduce installation costs while delivering outstanding reliability, comprehensive functionality and selectable high-security or standard speeds. With the

D2 Turbo Low-Voltage, there is no need for costly high-voltage cable runs and expensive isolators. Simply use a low-voltage step-down transformer or solar power supply.



MAIN FEATURES

Mechanical Features

- Battery backup
- Turbo speed for greater security and convenience
- Tough-as-nails steel pinion
- Very easy to install and set up, saving you time and money
- Easy mounting with a revolutionary jacking system
- Lockable, easy manual override
- Modular components clip together for easy maintenance

Electronic Features

- Simple user interface makes changing settings child's play
- Insect-proof controller housing with removable terminals
- Multiple Modes of Operation with enhanced user interface for exceptionally easy and versatile installation
- Adaptive Collision Sensing – intelligent enough to adapt to changes in the track, but sensitive enough to keep your loved ones safe
- Opening and Closing Safety Beam Inputs with beam circuit functional test
- High-security cleared beam Autoclose, in conjunction with Safety Beams (PIRAC)
- Automatic closing with adjustable time delay, and pushbutton override
- Remote gate-status indicator (gate position, power failure, low battery, multiple collision detection and Pillar Light Status indication)
- Pedestrian Opening

- Holiday Lockout
- Courtesy/Pillar Light (fixed duration), with pre-delays and two Pre-flashing Modes
- Selectable gate speed modes – Low Speed/High Speed (High Speed is the default)
- Positive Close Mode (e.g. to ensure activation of electric fence contact switch)
- Onboard multichannel CENTURION code-hopping receiver with the ability to learn remote control buttons to specific functions (e.g. Gate Trigger, Pedestrian Opening, Holiday Lockout)
- Low-voltage AC or DC input - perfect for installations where there is no mains power at the gate (**D2 Turbo Low-Voltage**)
- Solar power-ready - energy-efficient, environmentally-friendly and offering greater autonomy

TECHNICAL SPECIFICATIONS

Technical Data	D2 Turbo	D2 Turbo Low-Voltage
Input voltage ¹	90V– 240V AC ±10%, 50Hz	10V - 20V AC ±10%, 50Hz; 10V - 28V DC ²
Motor voltage	12V DC	12V DC
Motor power supply ³	Battery-driven (standard capacity - 12V 5Ah)	Battery-driven (standard capacity - 12V 5Ah)
Battery charger ¹	Intergral with controller 1A @ 13.7V +/- 1%	Intergral with controller 1A @ 13.7V +/- 1% (Input voltage > 15V AC)
Current consumption (mains)	60mA	60mA
Current consumption (motor at rated load)	8/12A	8/12A
Current consumption (quiescent load)	95mA	95mA
Operator push force		
Starting	18kgf	18kgf
Rated	8kgf	8kgf
Gate mass – maximum	250kg	250kg
Gate length - maximum	20m	20m
Gate speed - m/min ⁵	22 - 26m/min	22 - 26m/min
Gate speed - mm/sec	367 - 433mm/sec	367 - 433mm/sec
Drive Pinion	17T Module 4	17T Module 4
Maximum daily cycle	10 cycles/day	10 cycles/day
Design life	30 000 cycles	30 000 cycles
Operations in standby with standard battery ^{3, 4}		
Half day	60 cycles	60 cycles
Full day	40 cycles	40 cycles
Collision sensing	Electronic	Electronic
Operating temperature	-15°C to +50°C	-15°C to +50°C
Degree of protection	IP54	IP54
Controller incorporated	D2 Controller_H	D2 Controller_L
Onboard receiver type	NOVA code-hopping onboard, multichannel	NOVA code-hopping onboard, multichannel
Receiver frequency	433.92MHz	433.92MHz
Receiver code storage capacity	32 transmitter buttons	32 transmitter buttons
Mass of unit packed	5kg	5kg
Packaging dimensions	Length: 255mm x Width: 188mm x Height: 333mm	Length: 255mm x Width: 188mm x Height: 333mm

1. Can operate off a solar supply, consult Centurion Systems for assistance
2. Plug-in transformer
3. Can increase battery capacity for longer standby times
4. Based on 4m gate with no external accessories such as infrared Safety Beams
5. Gate operating speed can be configured to run at a slower, 16m/min, depending on the requirements of individual installations

D2 Turbo single operator duty cycle as a function of operating time

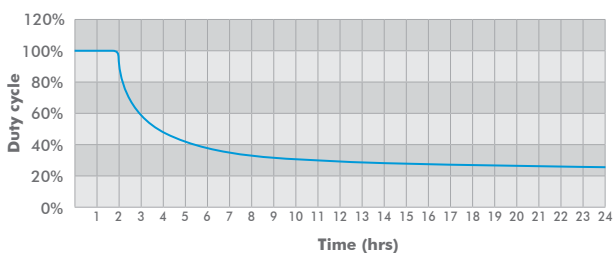



CABLING REQUIREMENTS

- D2 Turbo:** 220V - 240V AC mains cable via double mains isolator switch (3 core LNE 1.5mm² SWA)¹
D2 Turbo Low-Voltage: 10V - 20V AC cable via transformer in dwelling (3 core LNE 1.5mm² Surfex)

Optional Wiring (all cable is multi-stranded):

- Intercom, cable from control box to dwelling (n1⁶ + 6 core³ 0.5mm² multi-stranded) or cable from control box to entry panel (n2⁶ 0.5mm² multi-stranded)
 - Infrared Safety Beams (3 core 0.5mm² multi-stranded)
 - Access control device (3 core 0.5mm² multi-stranded⁴)
 - Pedestrian keyswitch (2 core 0.5mm² multi-stranded) or
 - Keypad (3 core 0.5mm² multi-stranded)
 - External radio receiver (3 core 0.5mm² multi-stranded⁵)
 - Pillar Lights (3 core LNE SWA², size according to power requirements)
 - Inductive loop detector for free-exit (1 core 0.5mm² multi-stranded - silicone-coated⁶)
1. Possibly increase cable thickness if Pillar Lights are to be installed
2. SWA - steel wire armoured. Type of cable must adhere to municipal bylaws and preferably be screened. Screening provides better protection against lightning - earth one end of the screening
3. Allows for all features such as Pedestrian Opening, Status LED, etc. to be operated from the intercom handset inside the dwelling
4. Number of cores and type of cable could vary depending on the brand of access control system being used
5. For optimum range an external radio receiver can be mounted on the wall
6. Number of cores required by the intercom

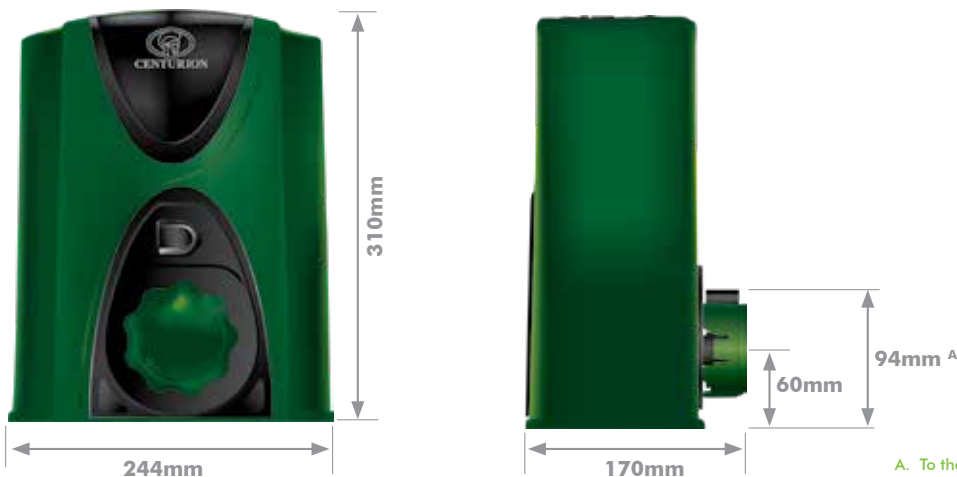

A. To the centre of the tooth mesh point of the rack



DON'T JUST THINK OF THE GREEN MOTOR... THINK OF BEING PART OF THE FAMILY!

Nothing beats a good story, and the story of how CENTURION became the South African market leader in gate automation has all the ingredients of a truly epic tale.

It all started when husband and wife team Pat and Anne Dickens – our heroes, if you will – embarked on an epic quest to bring security and convenience to the masses. As with any narrative, there was no shortage of challenges and obstacles along the way, and the fledgling company faced many of the hardships that often befall new businesses. The fact that gate automation was virtually unknown in South Africa at the time, coupled with a complicated and changing macro environment, must have made introducing a completely new concept particularly difficult.

How, then, has CENTURION managed to thrive and grow into the access automation giant that it is today?

The truth is that there is no single thing that enabled the brand to become a household name, but rather a combination of compelling innovation, a commitment to quality and a brand essence built upon making life easier for its many customers.

But perhaps the single most important element

that has endured for the past thirty years is a sense of family.

Indeed, Pat and Anne were joined very early on by Anne's brother, Richard Rohman – now the company's managing director – and the three Dickens boys have all served in the CENTURION ranks at one time or another, lending their considerable skills in the fields of finance, engineering and information technology to the business' growing pool of talent.

However, the Dickens' emphasis on community and family values has never been limited to those who are related to them, but is shared by every CENTURION employee. In fact, it is far from uncommon for a member of the team to refer to their colleagues as the "CENTURION family". This culture even extends into the way that we treat our customers, and we go to great lengths to treat every person who deals with us with honesty, integrity and respect, as we would an actual family member.

When you choose CENTURION for your access automation needs, you are never merely a customer; you are part of a great tradition built upon the bedrock of that most sacred of units: the family.

What does it mean to be part of the CENTURION family?

- It means that you will always receive world-class service and support
- It means that you will deal with warm and friendly staff
- It means that you will be treated with honesty and respect
- It means that, no matter who you are or where you're from, you'll always feel at home with the green gate motor brand



D5-EVO AND D5-EVO LOW-VOLTAGE DOMESTIC AND LIGHT-INDUSTRIAL SLIDING GATE OPERATORS

D5-Evo: The light-industrial **D5-Evo** is an evolution of the tried and tested D5, 500kg operator for domestic and light-industrial applications. Potent push force, along with intelligent speed control and smooth opening and closing, makes the **D5-Evo** the automatic choice for large private residences and townhouse complexes requiring reliable, feature-rich gate automation.

D5-Evo Low-Voltage: This model enables you to enjoy all the amazing features and functionality of the flagship

D5-Evo – even if you don't have mains power at the gate. All that is needed to breathe life into the feature-rich LCD controller is a low-voltage input, easily obtainable via a step-down transformer, dramatically reducing installation costs.



MAIN FEATURES

Mechanical Features

- Battery backup
- Lockable, easy manual override
- Custom-engineered gearbox molded from durable engineering polymer
- Save on cabling costs - no thick, expensive high-voltage cables (**D5-Evo Low-Voltage**)
- No need to fit costly isolators (**D5-Evo Low-Voltage**)

Electronic Features

- LCD interface - exceptionally easy setup with visual and audible diagnostics and notifications
- Advanced diagnostic screens indicating:
 - Battery-low
 - Battery charge level
 - Fuse blown
 - High current draw
 - Details of the last transmitter activated
 - Health of the drive electronics
 - Currently-activated gate inputs
- See *Diagnostics Made Easy* booklet for further details
- Intelligent speed control - high-speed for greater security and convenience; slower speed for increased safety
- Local test button can be deactivated for added security
- Sensitive anti-crushing protection for greater safety
- Integrated ChronoGuard timer functionality (a world first) - Time-barring and Auto-activation features for switching on Pillar Lights, deactivating ground loops, etc.
- Multiple operating features including Intruder-detection Alarm Modes (a world first)
- Remote gate-status indicator (gate position, power failure, low battery, multiple collision detection and Pillar Light Status indication)
- Onboard multichannel CENTURION code-hopping receiver incorporating the following functionality:
 - Selective add and delete
 - Onboard receiver can be disabled
 - 500 transmitter button memory
 - Automatic maintenance features like Delete-Not-Present
- Opening and Closing Safety Beam Inputs
- Integrated Beam Test hardware to ensure the beams are always working correctly

TECHNICAL SPECIFICATIONS

Technical Data	D5-Evo	D5-Evo Low-Voltage
Input voltage	220V AC +/-10% @ 50Hz ¹	15V - 19V AC ^{2,3}
Motor voltage	12V DC	12V DC
Motor power supply ⁴	Battery-driven (standard capacity - 12V 7Ah)	Battery-driven (standard capacity - 12V 7Ah)
Battery charger	CP84SM - 1.8A @ 13.7 +/-1%	CP84XTE - 800mA @ 13.7 +/- 1%
Current consumption (mains supply)	60mA	60mA
Current consumption (motor rated / peak load)	8/15A	8/15A
Current consumption (quiescent load)	75mA	75mA
Operator push force		
Starting	30kgf	30kgf
Rated	17kgf	17kgf
Gate mass - maximum	500kg	500kg
Gate length - maximum	100m	100m
Gate speed - m/min ⁶	18 - 22m/min	18 - 22m/min
Gate speed - mm/sec	300 - 367mm/sec	300 - 367mm/sec
Drive Pinion	17T Module 4	17T Module 4
Maximum daily cycle	150 cycles/day	150 cycles/day
Design life	150 000 cycles	150 000 cycles
Operations in standby with standard battery ^{4,5}		
Half day	70 cycles	70 cycles
Full day	60 cycles	60 cycles
Collision sensing	Electronic	Electronic
Operating temperature	-15°C to +50°C	-15°C to +50°C
Degree of protection	IP54	IP54
Controller incorporated	D-Series_12	D-Series_12
Onboard receiver type	NOVA code-hopping onboard, multichannel	NOVA code-hopping onboard, multichannel
Receiver frequency	433.92MHz	433.92MHz
Receiver code storage capacity	500 transmitter buttons	500 transmitter buttons
Mass of unit packed	10kg	10kg
Packaging dimensions	Length:303mm x Width: 231mm x Height: 432mm	Length:303mm x Width: 231mm x Height: 432mm

1. Can operate off a solar supply, consult Centurion Systems for assistance
2. Plug-in transformer
3. Solar panel
4. Can increase battery capacity for longer standby times
5. Based on 4m gate with no external accessories such as infrared Safety Beams
6. Gate operating speed can be set slower depending on requirements of individual installations.

D5-Evo single operator duty cycle as a function of operating time

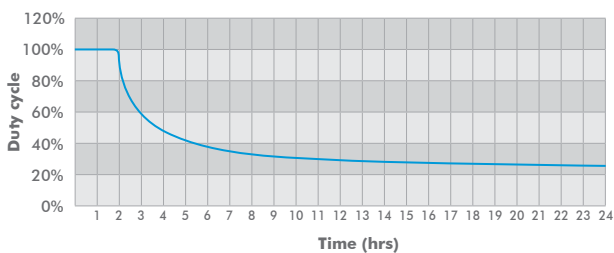



CABLING REQUIREMENTS

1. **D5-Evo: 220V** - 240V AC mains cable via double mains isolator switch (3 core LNE 1.5mm² SWA)¹
D5-Evo Low-Voltage: 15V - 19V AC cable via transformer in dwelling (3 core LNE 1.5mm² Surfex)

Optional Wiring (all cable is multi-stranded):

2. Intercom, cable from control box to dwelling (n1⁶ + 6 core³ 0.5mm² multi-stranded) or cable from control box to entry panel (n2⁶ 0.5mm² multi-stranded)
3. Infrared Safety Beams (3 core 0.5mm² multi-stranded)
4. Access control device (3 core 0.5mm² multi-stranded⁴)
5. Pedestrian keyswitch (2 core 0.5mm² multi-stranded) or
6. Keypad (3 core 0.5mm² multi-stranded)
7. External radio receiver (3 core 0.5mm² multi-stranded⁵)
8. Pillar Lights (3 core LNE SWA², size according to power requirements)
9. Inductive loop detector for free-exit (1 core 0.5mm² multi-stranded - silicone-coated⁶)

1. Possibly increase cable thickness if Pillar Lights are to be installed
2. SWA - steel wire armoured. Type of cable must adhere to municipal bylaws and preferably be screened. Screening provides better protection against lightning - earth one end of the screening
3. Allows for all features such as Pedestrian Opening, Status LED, etc. to be operated from the intercom handset inside the dwelling

4. Number of cores and type of cable could vary depending on the brand of access control system being used
5. For optimum range an external radio receiver can be mounted on the wall
6. Number of cores required by the intercom

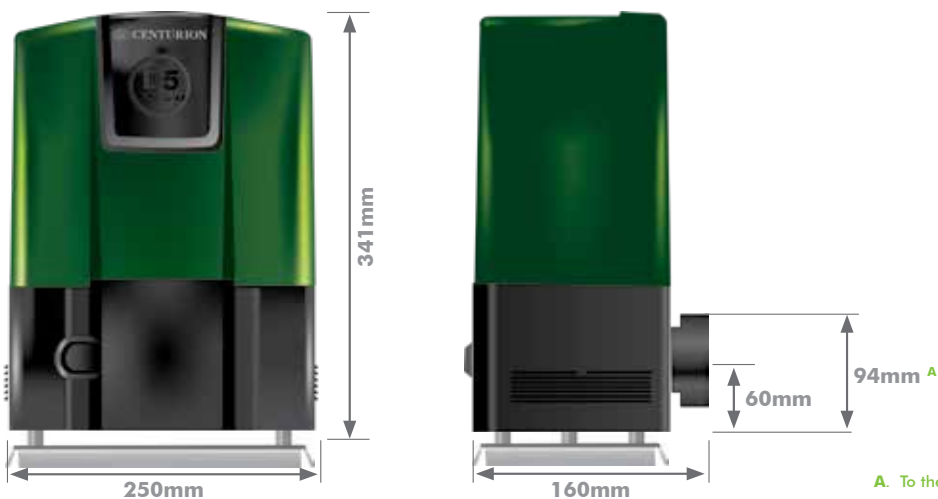

A. To the centre of the tooth mesh point of the rack



MAKE CENTURION PART OF YOUR NEXT BIG PROJECT

Planning your next big commercial project? CENTURION's range of powerful access control solutions offers exceptional security at every touchpoint and, with their tough construction and outstanding reliability, are able to meet the demands of even the most challenging of sites. Our solutions are built strong to withstand the harshest conditions, combining cutting edge technology with the finest quality electrical and mechanical components to deliver unsurpassed security, convenience and peace of mind.

AUTOMATION PERFECTION FOR DOORS

Seamlessly blending stunning aesthetics, whisper-quiet operation and innovative technology, CENTURION automatic doors create a superior user experience while delivering futuristic functionality with a flair for the fantastic.

Main features:

- Compact and elegant design
- Smooth and silent operation
- Intelligent monitoring of door movement in real time
- Maximum installation flexibility
- Incorporates state-of-the-art energy-saving technology



TRAFFIC BARRIERS



HIGH-VOLUME, HIGH-SECURITY INDUSTRIAL TRAFFIC BARRIERS

Main features:

- Reliable battery backup
- High-volume capability – up to 3000 operations per day
- Easy setup thanks to LCD user interface

BOLLARDS



EXCEPTIONAL SECURITY FOR HIGH-RISK SITES

Main features:

- Robust construction
- Designed for simplified installation and maintenance
- Crash-rated bollards are suitable for anti-terrorism applications

TURNSTILES



ESSENTIAL PEDESTRIAN ACCESS CONTROL

Main features:

- Easy installation
- Minimal wiring required
- Anti-tamper design
- Maintenance-free mechanism
- Improves security and enhances operational efficiency



D10 AND D10 TURBO INDUSTRIAL SLIDING GATE OPERATORS

D10: Using CENTURION's proven 24V DC technology, this is the complete solution for commercial and industrial gates weighing up to 1000kg. A rock-solid die-cast aluminium gearbox and reliable battery backup make the **D10** ideally-suited for complexes with large gates and high traffic volumes, while an intelligent LCD controller with multiple Modes of Operation makes setup and diagnostics veritable child's play.

D10 Turbo: CENTURION's fastest operator yet! This is the ideal solution for extremely fast, feature-rich and high-security gate automation. With a top speed of 833 millimetres per second and all the amazing features that first made the **D10** a favourite among installers and end-users alike, the **D10 Turbo** offers the complete package of brains, brawn and fast speed.

D10



D10 TURBO



MAIN FEATURES

Mechanical Features

- Battery backup
- Lockable, easy manual override with anti-jamming
- Strong die-cast aluminium gearbox
- High-volume capability - for greater reliability in intensive use applications

Electronic Features

- Turbo speed for greater security and convenience (**D10 Turbo**)
- LCD interface – Exceptionally easy setup with visual and audible diagnostics and notification
- Diagnostic screens indicating:
 - Battery-low
 - Battery charge level
 - Motor fuse blown
 - High current draw
 - Details of the last transmitter activated
 - Health of the drive electronics
 - Currently activated gate inputs
 - See Diagnostics Made Easy booklet for further details
- High duty cycle capability - for greater reliability in high-volume applications
- Sensitive anti-crushing protection for greater safety
- Intelligent speed control - high-speed for greater security and convenience; slower speed for increased safety
- Integrated ChronoGuard timer functionality (a world first) - Time-barring and auto-activation features for switching on Pillar Lights, deactivating ground loops, etc.
- Multiple operating features, including Intruder-detection Alarm Modes (a world first)
- Onboard CENTURION code-hopping multichannel receiver incorporating the following functionality:
 - Selective add and delete
 - Onboard receiver can be disabled
 - 500 transmitter button memory
 - Automatic maintenance features like Delete-Not-Present
- Opening and Closing Safety Beam Inputs
- Integrated Beam Test hardware to ensure that the beams are always working correctly

TECHNICAL SPECIFICATIONS

Technical Data	D10	D10 Turbo
Input voltage ¹	220V AC +/-10% @ 50Hz	220V AC +/-10% @ 50Hz
Motor voltage	24V DC	24V DC
Motor power supply ²	Battery-driven (standard capacity - 2 x 7Ah)	Battery-driven (standard capacity - 2 x 7Ah)
Battery charger	D10CHGRV02 – 1.8A @ 27.4V +/- 1%	D10CHGRV02 – 1.8A @ 27.4V +/- 1%
Current consumption (mains supply)	250mA	250mA
Current consumption (motor rated / peak load)	6/15A	8/15A
Current consumption (quiescent load)	80mA	80mA
Operator push force		
Starting	40kgf	20kgf
Rated	30kgf	15kgf
Gate mass – maximum	1000kg	240kg
Gate length - maximum	100m	50m
Gate speed - m/min	22 - 26m/min	43 - 51m/min
Gate speed - mm/sec	367 - 433mm/sec	717 - 850mm/sec
Drive Pinion	17T Module 4	20T Module 4
Maximum daily cycle	750 cycles/day	750 cycles/day
Design life	250 000 cycles	250 000 cycles
Operations in standby with standard battery ^{2, 3}		
Half day	120 cycles	120 cycles
Full day	100 cycles	100 cycles
Collision sensing	Electronic	Electronic
Operating temperature	-15°C to +50°C	-15°C to +50°C
Degree of protection	IP54	IP54
Controller incorporated	D-Series_24	D-Series_24
Onboard receiver type	NOVA code-hopping onboard, multichannel	NOVA code-hopping onboard, multichannel
Receiver frequency	433.92MHz	433.92MHz
Receiver code storage capacity	500 transmitter buttons	500 transmitter buttons
Mass of unit packed	13kg	13kg
Packaging dimensions	Length:355mm x Width: 288mm x Height: 485mm	Length:355mm x Width: 288mm x Height: 485mm

1. Can operate off a solar supply, consult Centurion Systems for assistance
2. Can increase battery capacity for longer standby times
3. Based on 4m gate with no external accessories such as infrared Safety Beams

D10 and D10 Turbo single operator duty cycle as a function of operating time

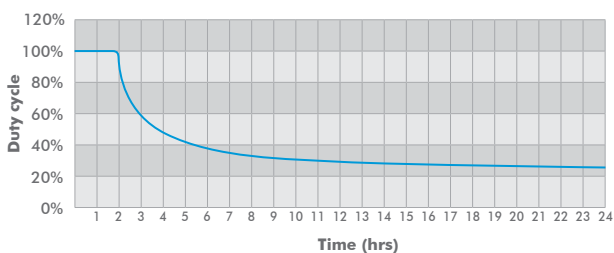

D10 Turbo maximum operating speed for corresponding gate mass

Gate mass	Maximum running speed
240kg	50m/min
300kg	42m/min
400kg	36m/min
500kg	32m/min
600kg	29m/min
700kg	27m/min
800kg	25m/min
900kg	24m/min
1000kg	23m/min





CABLING REQUIREMENTS

1. 220V - 240V AC mains cable via double pole mains isolator switch (3 core¹ LNE 1.5mm² SWA²)

Optional Wiring (all cable is multi-stranded):

2. Intercom, cable from control box to dwelling (n1⁶ + 6 core³ 0.5mm² multi-stranded) or cable from control box to entry panel (n2⁶ 0.5mm² multi-stranded)
 3. Infrared Safety Beams (3 core 0.5mm² multi-stranded)
 4. Access control device (3 core 0.5mm² multi-stranded⁴)
 5. Pedestrian keyswitch (2 core 0.5mm² multi-stranded) or
 6. Keypad (3 core 0.5mm² multi-stranded)
 7. External radio receiver (3 core 0.5mm² multi-stranded⁵)
 8. Pillar Lights (3 core LNE SWA², size according to power requirements)
 9. Ground loop for free-exit (1 core 0.5mm² multi-stranded - silicone-coated⁶)
1. Possibly increase cable thickness if Pillar Lights are to be installed
 2. SWA - steel wire armoured. Type of cable must adhere to municipal bylaws and preferably be screened. Screening provides better protection against lightning - earth one end of the screening
 3. Allows for all features such as Pedestrian Opening, Status LED, etc. to be operated from the intercom handset inside the dwelling
 4. Number of cores and type of cable could vary depending on the brand of access control system being used
 5. For optimum range an external radio receiver can be mounted on the wall
 6. Number of cores required by the intercom

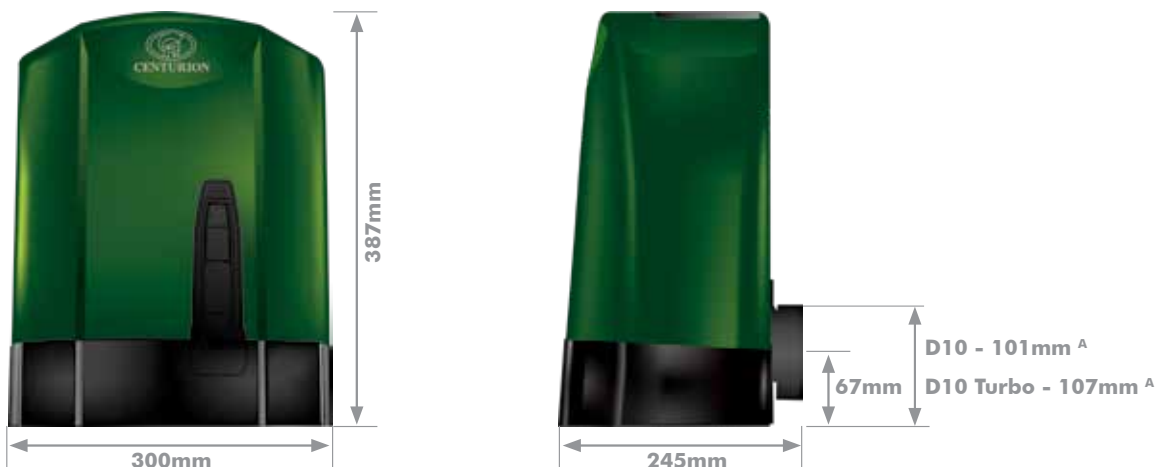

A. To the centre of the tooth mesh point of the rack

GIVE YOUR CLIENTS MORE SECURITY & PEACE OF MIND



WITH CENTURION'S EXTENDED COMMERCIAL RANGE

Planning your next big commercial project? CENTURION's range of powerful access control solutions offer exceptional security at every touchpoint and, with their tough construction and outstanding reliability, are able to meet the demands of even the most challenging of sites.

DOOR AUTOMATION SOLUTIONS

With a host of innovative technological features, our ASDs are putting a fresh spin on an established access control system and helping you to open doors for your business!

- The best long-term performance in the industry
- Outstanding reliability using only the best quality electronic and mechanical components
- Thin and elegant with compact dimensions
- Energy saving
- Smooth and silent operation



TURNSTILES

Turn to us for the very best turnstiles, offering improved reliability, simplified maintenance, modern design and IP65-rated protection, to name but a few innovative features.



A10 ENDURANCE AND A10 HEAVYWEIGHT INDUSTRIAL SLIDING GATE OPERATORS

Using a powerful three-phase motor, the **A10** is the ultimate industrial automation solution. Since this beast is mains-powered, it is able to provide an almost unlimited duty cycle with rapid opening and closing courtesy of a die-cast aluminium gearbox and intelligent controller-inverter pairing.

A10 Endurance:

A rapid and robust operator with a three-phase motor for commercial and industrial gates up to 1000kg.

A10 Heavyweight:

An all-round performer for gates up to 2000kg.



MAIN FEATURES

Mechanical Features

- High push force for reliable operation of almost any gate
- High duty cycle capability - for greater reliability in high-volume applications
- Strong die-cast aluminium gearbox with anti-jamming

Electronic Features

- Extremely rapid operating speed - up to 30 metres per minute offers exceptional security and high-volume access control
- Multiple programmable features - to suit a wide variety of applications
- Optional DC Converter for reliable battery backup with full kit (DC_CONKITL):
 - On-demand battery backup protection
 - Brown-out power failure detection
 - Battery-protection circuitry
 - Integrated battery charger
- Proven lightning protection
- Pedestrian Opening input – prevents unauthorised vehicle access
- Safety Beam input – connecting infrared safety beams dramatically increases the safety of the automated system
- Local and remote multi-function Gate Status LED
- Free-exit input (only opens gate)
- Timed potential-free contact (e.g. Courtesy Lights)

- Selectable/adjustable Autoclose timer (1 - 255 seconds)
- Override of Autoclose timer via trigger input
- Local diagnostic LEDs for easy programming diagnostics
- 12V DC auxiliary supply connecting safety beams, external receivers, keypads, etc.

TECHNICAL SPECIFICATIONS

Technical Data	A10 Endurance		A10 Heavyweight
Input voltage ¹	220V AC +/-10% @ 50Hz		220V AC +/-10% @ 50Hz
Motor voltage	220V AC 3 phase		220V AC 3 phase
Motor power supply	Frequency inverter		Frequency inverter
Current consumption (mains supply)	6A		6A
Operator push force	Standard	Sprint	
Starting	40kgf	25kgf	40kgf
Rated	30kgf	22.5kgf	NA
Gate mass – maximum	1000kg	600kg	2000kg
Gate length - maximum	20m		20m
Gate speed - m/min	16m/min	30m/min	13.6m/min
Gate speed - mm/sec	267mm/sec	500mm/sec	267mm/sec
Drive Pinion	20T Module 4		20T Module 4
Maximum daily cycle	Lockable lever with key release		750 cycles/day
Design life	1 000 000 cycles		1 000 000 cycles
Collision sensing	Electronic		Electronic
Operating temperature	-20°C to +50°C		-20°C to +50°C
Degree of protection	IP54		IP54
Controller incorporated	CP200E / CP201		CP200E / CP201
Mass of unit packed	15.5kg		15.5kg
Packaging dimensions	Length:355mm x Width: 288mm x Height: 485mm		Length:355mm x Width: 288mm x Height: 485mm

Technical Data	DC Converter
Input voltage	12V DC
Current draw @ rated thrust	30A
Rated output voltage	310V DC
Battery charger output	2A
Duty cycle ²	20%
Thermal protection	Electronic
Degree of protection	IP65
Battery capacity ³	Minimum 12V 7Ah but external 35Ah is recommended
Operating cycles per Ah of capacity	Minimum 1 open or close cycle
Packaging dimensions	Length: 269mm x Width: 145mm x Height: 365mm

1. Can operate off a solar supply, consult Centurion Systems for assistance
2. Based on 25°C ambient temperature and unit not in direct sunlight
3. Battery housed in separate enclosure

A10 single operator duty cycle as a function of operating time

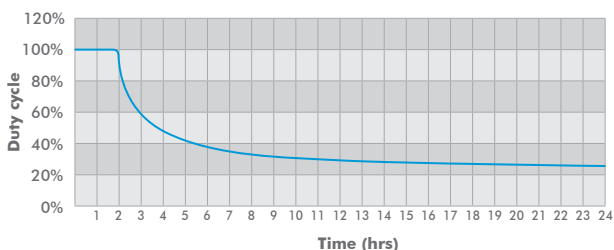



CABLING REQUIREMENTS

1. 220V - 240V AC mains cable via double pole mains isolator switch (3 core¹ LNE 1.5mm² SWA²)

Optional Wiring (all cable is multi-stranded):

2. Intercom cable from control box to dwelling (n1⁶ + 6 core² 0.5mm² multi-stranded) or cable from control box to entry panel (n2⁶ 0.5mm² multi-stranded. Infrared Safety Beams (3 core 0.5mm² multi-stranded)
3. Access control device (3 core 0.5mm² multi-stranded⁴)
4. Pedestrian keyswitch (2 core 0.5mm² multi-stranded) or
5. Keypad (3 core 0.5mm² multi-stranded)
6. External radio receiver (3 core 0.5mm² multi-stranded⁵)
7. Pillar Lights (3 core LNE SWA², size according to power requirements)
8. Inductive loop detector for free-exit (1 core 0.5mm² multi-stranded - silicone-coated⁶)

1. Possibly increase cable thickness if Pillar Lights are to be installed
2. SWA - steel wire armoured. Type of cable must adhere to municipal bylaws and preferably be screened. Screening provides better protection against lightning - earth one end of the screening
3. Allows for all features such as Pedestrian Opening, Status LED, etc. to be operated from the intercom handset inside the dwelling

4. Number of cores and type of cable could vary depending on the brand of access control system being used

5. For optimum range an external radio receiver can be mounted on the wall

6. Number of cores required by the intercom

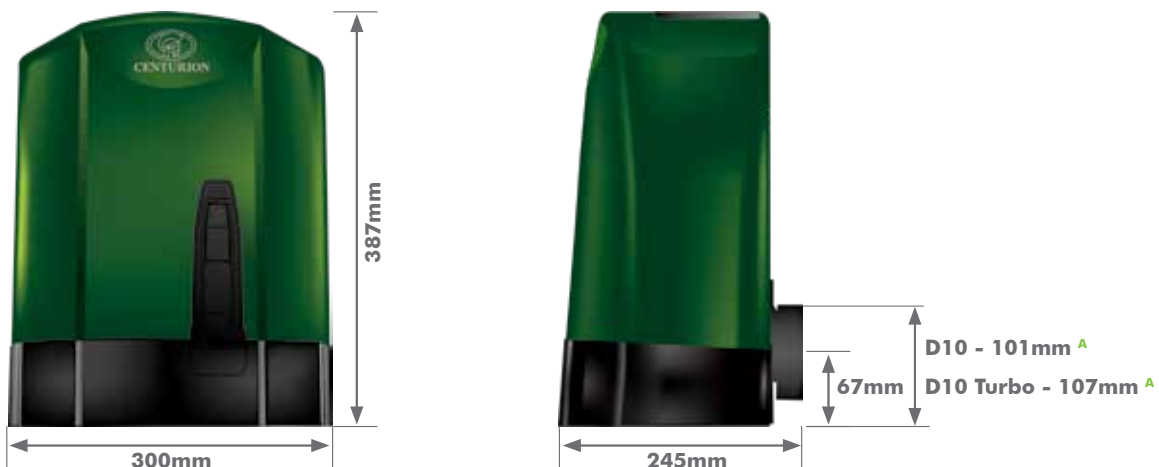

A. To the centre of the tooth mesh point of the rack

MAKING YOUR LIFE EASIER



WITH OUR VERSATILE WIRELESS SOLUTION

We believe in creating products that **make your life easier**.

It is this philosophy, and our dedication to **changing the world through the power of technology**, that informs every aspect of this **complete solution for wireless control**.

G-ULTRA)))



THE ULTIMATE GSM SOLUTION

- Monitor up to four electrical devices by receiving SMS/email/Missed Call notifications
- Use the outputs to control up to six devices from your phone (two additional onboard relays)
- Intelligent monitoring of CENTURION gate motors' status outputs (for example gate opening, gate left open, etc.)
- Suitable for a wide variety of access automation applications

wizo LINK



A WIRELESS WIRE

- Secure, robust mesh network
- Network fully expandable in size and range
- Control anything wirelessly
- Intelligent and flexible dual-role functionality – each node can act as a transmitter and/or receiver

G REMOTE



MOBILE APPLICATION

- Unbelievably cost-effective monitoring and control solution – costs less than 1c per activation or notification
- Activate device outputs with a single tap
- Choose from a range of custom icons to represent the functionality associated with each button
- Device monitoring via push notifications with the ability to block notifications for each individual phone
- App available for iOS and Android devices

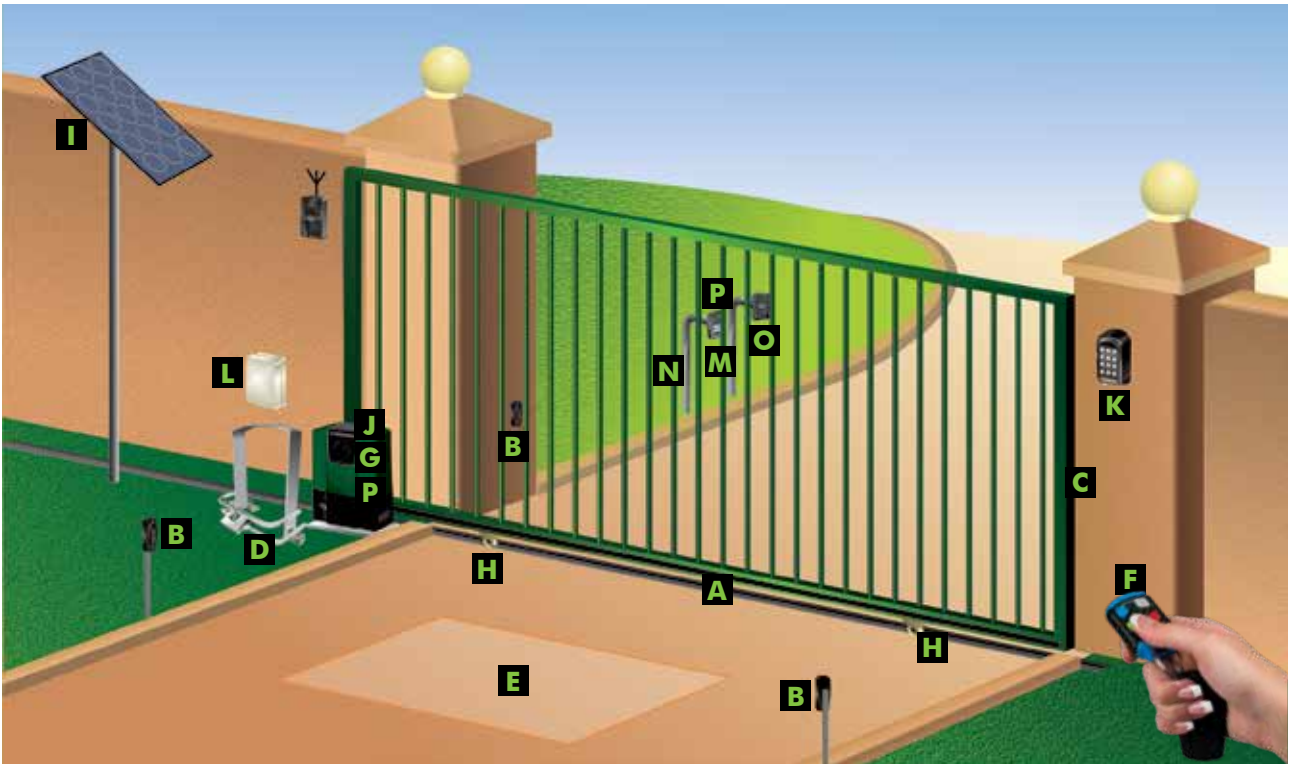

SLIDING GATE OPERATOR ACCESSORIES



STEEL, NYLON RAZER OR NYLON ANGLE RACK
A variety of rack available in different lengths, for different strengths.



CENTURION INFRARED SAFETY BEAMS
Always recommended on any gate automation installation to increase the safety of the automated system.



P36 PASSIVE SENSITIVE EDGE
Passive sensitive edge provides additional protection against crushing.



THEFT-RESISTANT CAGE
Retro-installable steel cage that increases the resistance of the operator against theft.



FLUX SA LOOP DETECTOR
Allows free-exit of vehicles from the property (requires ground loop to be fitted).



CENTURION NOVA TRANSMITTER
Incorporates ultra-secure code-hopping technology. Available in one-, two-, three- and four-button variants.

SLIDING GATE OPERATORS



BACKUP MEMORY MODULE

Back up all the transmitters and operating details set up in the controller.

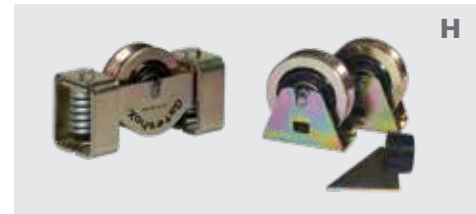

WHEEL KITS

A variety of wheel kits are available from Centurion Systems.



SOLAR SUPPLY

Alternative means of powering the system with our 20, 40, 60, 80, 120 or 150 Watt panels.



G-ULTRA GSM DEVICE

The ultimate new GSM solution for monitoring and activating electrical appliances via your mobile phone.



SMARTGUARD or SMARTGUARDAIR KEYPAD

Cost-effective and versatile wired or wireless keypad, allowing access for pedestrians.



A10 DC CONVERTER

Provides battery backup and power failure autonomy for the A10 operator.



POLOPHONE INTERCOM

Allows visitors to communicate with people inside in order to gain access to the property.



GOOSENECK

Steel pole for mounting intercom gate station or access control.



SOLO/LATTICE PROXIMITY ACCESS CONTROL

Proximity reader for allowing access for both pedestrians and vehicles.



G-SPEAK ULTRA

Allows you to answer your intercom from anywhere

SLIDING GATE OPERATOR KITS

D5 SMART FULL KIT

1

Product Code: D5SMARTFK_RAZ1 / D5SMARTFK_STEEL2 / SMARTFK_NYLON2

- **1 x D5 SMART operator including:**
 - 2 x 4 button CENTURION transmitters G
 - 1 x Foundation plate S
 - 1 x Controller A
 - 1 x 1.3A charger N
- 2 x Battery N
- 4m x RAZ rack/Steel rack/Nylon angle rack T

D2 TURBO FULL KIT

2

Product Code: D2TFULLKIT_RAZ1 / D2TFULLKIT_NYLON1
D2TFULLKIT_STEEL1

- **1 x D2 Turbo operator including:**
 - 2 x 4 button CENTURION transmitters G
 - 1 x Foundation plate P
 - 1 x Controller B
 - 1 x Integral 1A charger K
- 1 x 5Ah battery O
- 4m x RAZ rack/Steel rack/Nylon angle rack T

D2 TURBO LOW-VOLTAGE FULL KIT

2

Product Code: D2TFULLKIT_RAZ1LV / D2TFULLKIT_NYLON1LV
D2TFULLKIT_STEEL1LV

- **1 x D2 Turbo operator including:**
 - 2 x 4 button CENTURION transmitters G
 - 1 x Foundation plate P
 - 1 x Controller C
 - 1 x 800mA charger K
- 1 x 5Ah battery O
- 4m x RAZ rack/Steel rack/Nylon angle rack T

D5-EVO FULL KIT

3

Product Code: D5EVOFK_RAZ1 / D5EVOFK_STEEL2 / D5EVOFK_NYLON2

- **1 x D5-Evo operator including:**
 - 2 x 4 button CENTURION transmitters G
 - 1 x Foundation plate Q
 - 1 x Controller D
 - 1 x 2A charger L
- 1 x 7Ah Battery O
- 4m x RAZ rack/Steel rack/Nylon angle rack T

D5-EVO LOW-VOLTAGE FULL KIT

3

Product Code: D5EVOFK_RAZ1LV / D5EVOFK_STEEL2LV /
D5EVOFK_NYLON2LV

- **1 x D5-Evo operator including:**
 - 2 x 4 button CENTURION transmitters G
 - 1 x Foundation plate Q
 - 1 x Controller D
 - 1 x 800mA charger K
- 1 x 7Ah battery O
- 4m x RAZ rack/Steel rack/Nylon angle rack T

D10 FULL KIT

4

Product Code: D101R

- **1 x D10 Turbo operator including:**
 - 1 x Foundation plate R
 - 1 x Controller D
 - 1 x 2A 24V charger L
- 2 x 7Ah Battery O
- 4m x Steel rack T

D10 TURBO FULL KIT

4

Product Code: D101T_FULL KIT

- **1 x D10 Turbo operator including:**
 - 1 x Foundation plate R
 - 1 x Controller D
 - 1 x 2A 24V charger L
- 2 x 7Ah Battery O
- 4m x Steel rack T
- 2 x Sets i5 Safety Beams H
- 2m x Passive sensitive edge I

D10 TURBO PART KIT

4

Product Code: D101T_PART KIT

- **1 x D10 Turbo operator including:**
 - 1 x Foundation plate R
 - 1 x Controller D
 - 1 x 2A 24V Charger L
- 2 x 7Ah Battery O
- 2 x Sets i5 Safety Beams H
- 2m x Passive sensitive edge L

A10 ENDURANCE KIT

5

Product Code: A10ER

- **1 x A10 Turbo operator (20T Pinion) including:**
 - 1 x Foundation plate R
 - 1 x CP201 Controller F
 - 1 x CP200 Inverter J
- 4m x Steel rack T

A10 HEAVYWEIGHT KIT

5

Product Code: A10GR

- **1 x A10 Operator (17T Pinion) including:**
 - 1 x Foundation plate R
 - 1 x CP201 Controller I
 - 1 x CP200 Inverter N
- 4m x Steel rack T

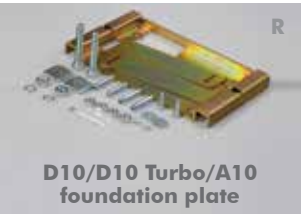



OUR DIGITAL AND ONLINE BRAND PRESENCE AND SUPPORT

WEBSITE

- Landing pages in French, Spanish, Portuguese and Thai
- Access to product documentation, comparison charts and diagnostic guides
- Device software
- G-WEB PLUS interface for administering CENTURION GSM devices
- Massive library of useful articles
- <http://www.centsys.com>

SUPPORT

- Dedicated technicians, unrivalled backup support and friendly and efficient sales personnel
- Technical support in all official languages, as well as French, Spanish and Portuguese
- Call centre operates 7am to 6pm (GMT +2), Monday to Friday and 8am to 4:30pm (GMT +2) on Saturdays

SOCIAL MEDIA

- “Like” our Facebook page (www.facebook.com/centurionsystems) and follow us on Twitter (@askCenturion) for all the exciting company news, launches, roadshows, competitions as well as technical and sales support
- Subscribe to our YouTube channel for access to an extensive library of how-to videos and tutorials
- Interesting and innovative installations from around the world, including unusual uses of CENTURION products
- Are you on our YouTube channel? Showcase your installations!

NEWSLETTER

- Fantastic way of staying abreast of company news, developments, events and functions, new products and enhancements to existing range



INDUSTRY-LEADING PRODUCT TECHNOLOGIES

TECHNOLOGY

CENTURION products feature a host of industry-leading technologies, all conducive to greater security, greater convenience and superior functionality. Just some of the advanced technologies found in our products are:

- **ChronoGuard** – a world-first timer technology that allows the user to set a myriad Auto-activation and Time-barring functions using the onboard Real Time Clock and Calendar, which tracks the date up to the year 2099
- **Intruder-detection Alarms** – The novel feature-set – consisting of the Beam Alarm and Ambush Alarm - ups the security ante even further by providing an audible output when the infrared gate safety beams are obstructed, or remain interrupted for a pre-defined period of time
- **Code-hopping technology** – CENTURION remote controls are equipped with code-hopping encoders which process the outgoing transmission through a sophisticated encryption engine, making copying and cloning virtually impossible. No two transmitted codes will ever be alike

- **Onboard diagnostics** – Our D-Series range provides both audible and visual feedback of the gate status at any given time. In addition, a designated diagnostic screen makes fault-finding a breeze
- **High-volume capability** – CENTURION operators are designed to work hard, and work hard they do – with some operators such as the SECTOR II traffic barrier being capable of performing in excess of 3000 operations every single day



Connect with us on

 facebook.com/CenturionSystems

 YouTube.com/CenturionSystems

 Twitter@askCenturion

 Instagram@centurion.systems

Newsletter subscription: www.centsys.com/Subscribe

www.centsys.com

**Sharecall 0860 CENTURION (0860 236 887)
+27 11 699 2400**

**Sharecall Technical Support 0861 003 123
+27 11 699 2481
from 07h00 to 18h00 (GMT+2)**

**Sharecall numbers applicable when dialled
from within South Africa only**

The products depicted are for illustrative purposes only. Actual products may differ.

E&OE. Centurion Systems (Pty) Ltd. reserves the right to change any product without prior notice.

All product and brand names in this document that are accompanied by the ® symbol are registered trademarks in South Africa and/or other countries, in favour of Centurion Systems (Pty) Ltd, South Africa. The Centurion Systems logo, all product and brand names in this document that are accompanied by the TM symbol are trademarks of Centurion Systems (Pty) Ltd, in South Africa and other territories; all rights are reserved.

We invite you to contact us for further details.